



AVK BALL CHECK VALVE, FLANGED, PN10/16

53/35-003

Ductile iron

AVK ball check valves are self-cleaning and with full bore. The ball rotates during operation eliminating the risk of impurities getting stuck on the ball. The full and smooth bore ensures full flow with low pressure loss and eliminates the risk of deposits at the bottom. AVK ball check valves are available with flanges and internal threads. They are delivered with NBR lined ball as standard and optionally with ball of polyurethane available in different weights.

Product description:

Ball check valve with flanges for wastewater treatment and neutral liquids to max. 70° C

Design standards:

- EN 12050-4
- Face-to-face dimension according to EN 558 Table 2 Basic Series 48
- Flange drilling to EN1092, PN10/16

Test/Approvals:

- Hydraulic test according to EN12050-4
- Approved according to 60143502, TÜV-Mark

Features:

- Self-cleaning construction, where the ball rotates during operation eliminating the risk of impurities getting stuck on the ball
- Full bore ensures low pressure loss and minimum back pressure
- Smooth bore eliminates the risk of deposits at the bottom
- NBR rubber line on a metal core to prevent the ball from getting stuck in the seat. In DN 600 the ball is of aluminium with PUR liner
- The ball is optionally available in polyurethane suitable for abrasive media and if different ball weights are necessary to prevent vibration and water hammer
- Compact design and low weight
- Bolts and nuts of stainless steel and body and cover of ductile iron with epoxy coating internally and externally according to AVK coating standard



Expect ... **AVR**

The designs, materials and specifications shown are subject to change without notice due to the continuous development of our product range.

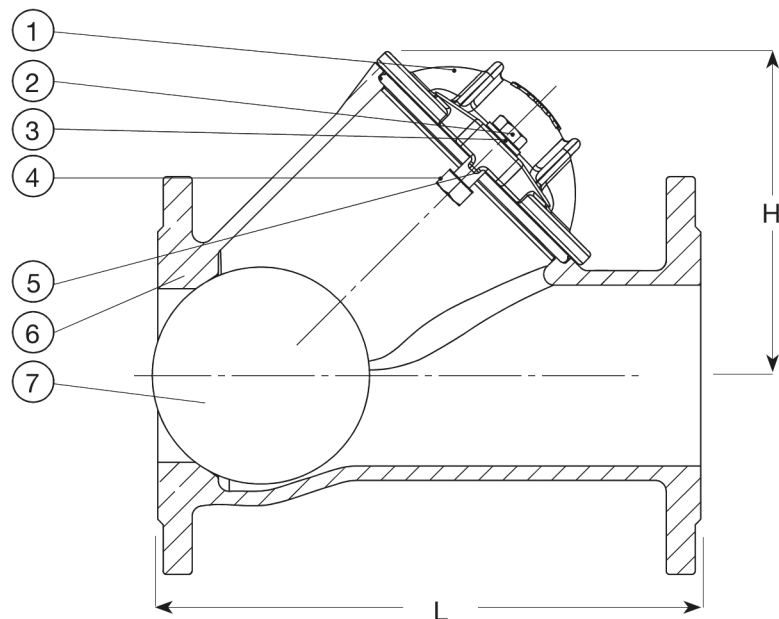

Component list:

1. Cover	Ductile iron GJS-500-7	5. O-ring	NBR rubber
2. Bolt	Stainless steel A2	6. Body	Ductile iron GJS-500-7
3. Washer	Stainless steel A2	7. Ball	NBR liner/metal core
4. Nut	Stainless steel A4, Delta Seal		

Components may be substituted with equivalent or higher class materials without prior notification.

Reference nos. and dimensions:

AVK ref. no.	DN mm	Product PN Class	Flange drilling	L mm	H mm	Theoretical weight/kg
53-050-35-1007	50	PN10	PN10/16	200	101	7.5
53-065-33-1007 ⁽¹⁾	65/80	PN10	PN10/16	240	148	11
53-065-35-1007	65	PN10	PN10/16	240	148	10
53-080-35-1007	80	PN10	PN10/16	260	148	12
53-100-35-1007	100	PN10	PN10/16	300	182	16
53-125-35-1007	125	PN10	PN10/16	350	251	35
53-150-35-1007	150	PN10	PN10/16	400	251	32
53-200-35-0007	200	PN10	PN10	500	333	68
53-200-35-1007	200	PN10	PN16	500	333	68
53-250-35-0007	250	PN10	PN10	600	406	93
53-250-35-1007	250	PN10	PN16	600	406	93
53-300-35-0007	300	PN10	PN10	700	480	124
53-300-35-1007	300	PN10	PN16	700	480	124
53-350-35-0007	350	PN10	PN10	800	571	231
53-350-35-1007	350	PN10	PN16	800	571	231
53-400-35-0007	400	PN10	PN10	900	657	416
53-400-35-1007	400	PN10	PN16	900	657	416
53-500-35-0007 ⁽²⁾	500	PN10	PN10	1100	930	712
53-600-35-0207 ⁽³⁾	600	PN10	PN10	1300	1010	1200

(1) DN65 drilled with DN80 ball (Ø95 mm)
 (2) Approximate TÜV test
 (3) Approximate TÜV test. Supplied with PUR lined ball as standard