



AVK SOCKET TEE TEE W/MECHANICAL JOINTS, PN16

712/1060-001



AVK's range of fittings comprises a wide selection of variants with socket and flange connection. The fittings are made of ductile iron GJS-500-7 and are epoxy coated according to DIN 30677-2 and GSK specifications - internally and externally.



Product description:

Socket Tee type MMB for DI pipes for water, waste water and neutral liquids to max. 70° C

Design standards:

- EN 545

Features:

- Ductile iron fitting to EN 545
- Body of GJS-500-7
- Epoxy coated to DIN 3476 and GSK internally and externally



Expect... **AVR**

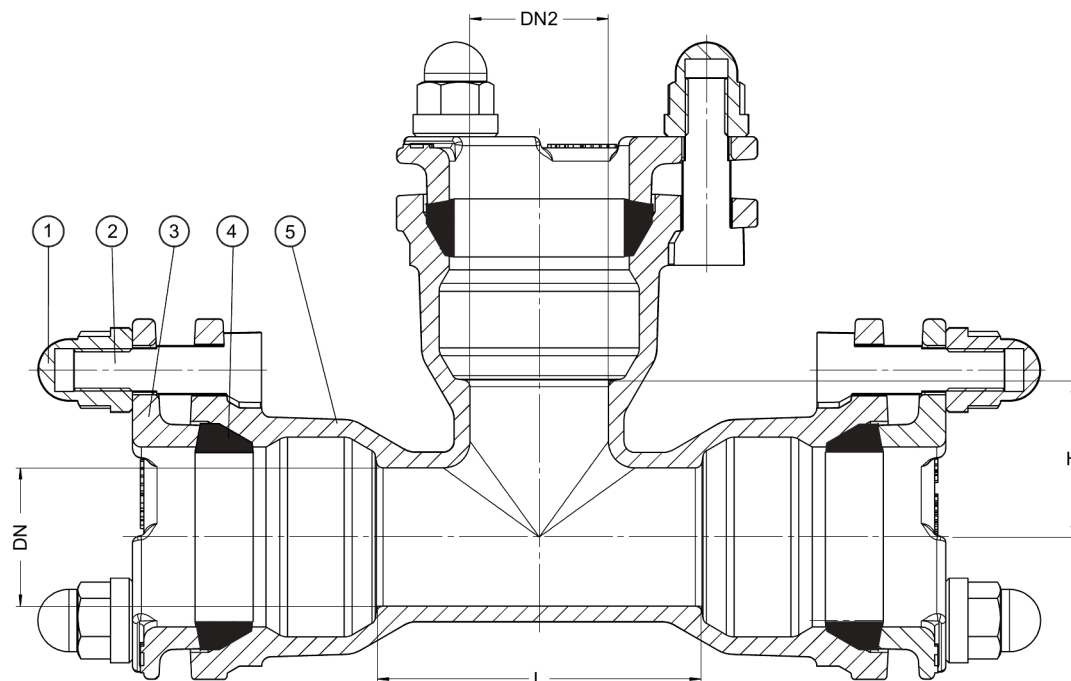

Component list:

1. Nut	Steel S235JR	4. Gasket	EPDM rubber
2. Bolt	Steel S235JR	5. Body	Ductile Iron
3. Gland flange	Ductile Iron		

Components may be substituted with equivalent or higher class materials without prior notification.

Reference nos. and dimensions:

AVK ref. no.	DN	DN2	L	H	Theoretical weight/kg
	mm	mm	mm	mm	
712-0060-10-601	60	60	145	70	14
712-0080-10-601	80	80	170	85	19
712-0100-10-601	100	100	190	95	22
712-0101-10-601	100	80	170	95	20
712-0125-10-601	125	125	225	110	28
712-0126-10-601	125	100	195	110	26
712-0127-10-601	125	80	170	105	24
712-0150-10-601	150	150	255	125	33
712-0152-10-601	150	100	195	120	31
712-0153-10-601	150	80	170	120	30
712-0200-10-601	200	200	315	155	56
712-0201-10-601	200	150	255	150	51
712-0203-10-601	200	100	200	145	45
712-0204-10-601	200	80	175	145	44
712-0250-10-601	250	250	374	190	74
712-0251-10-601	250	200	315	180	65
712-0252-10-601	250	150	260	175	59
712-0254-10-601	250	100	200	170	52