



## Installation, Operation and Maintenance Manual

### AVK Series 854 Ball Float Valve

The AVK 854 is a series of ball float valves designed to be fitted within a tank or in the top of a reservoir to control the filling and maintain a pre-determined water level.

The system operates by a float that closes the valve when rising and opens it when lowering.

The float is made of polypropylene or stainless steel, the internal valve parts are copper alloy and the valve housing is epoxy coated ductile iron.

Level difference between fully open and fully closed is between 170 mm for DN 50 to 930 mm for DN 300.



## 1. AVK series 854 exploded view

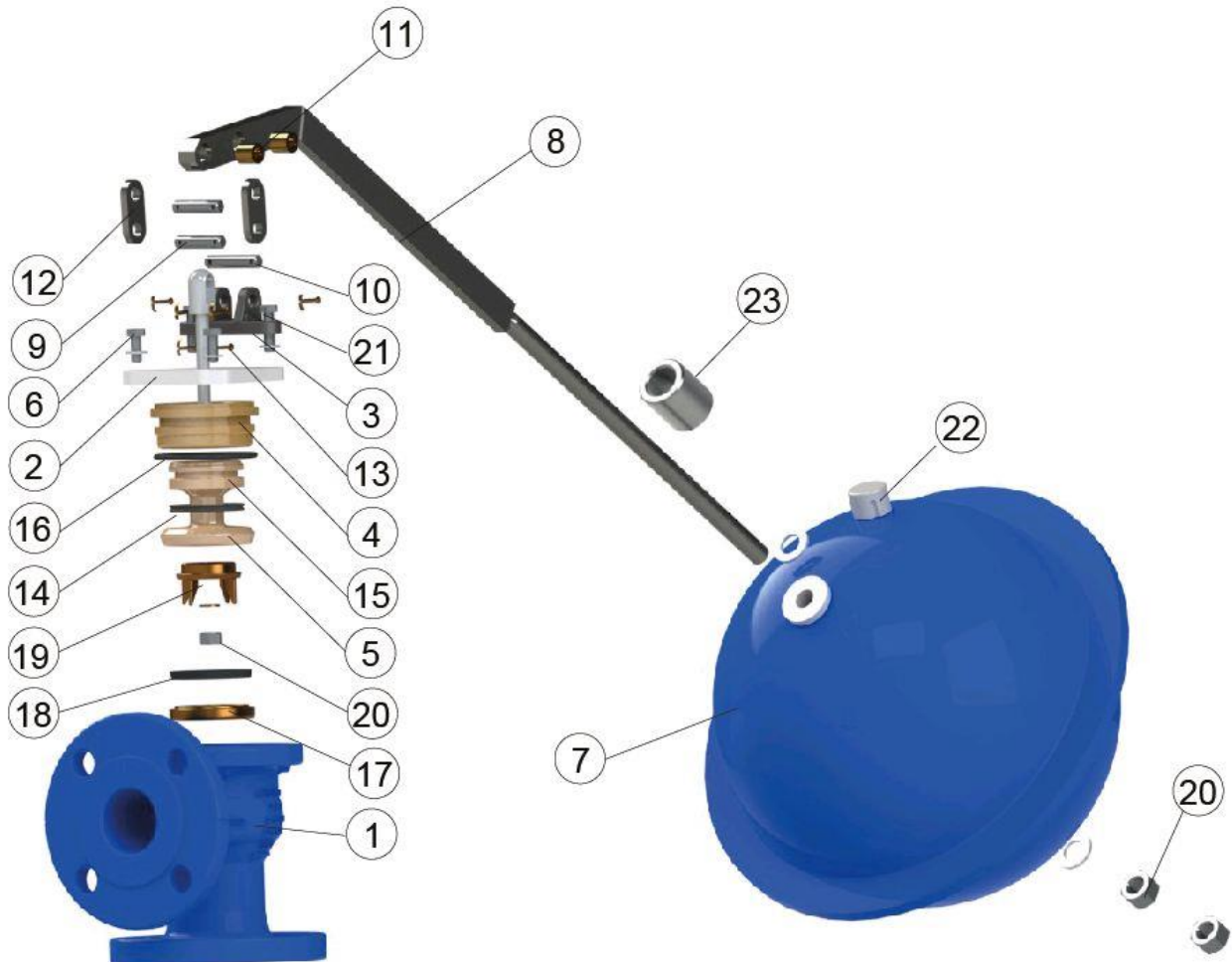

## 2. AVK series 854 parts list

Item	Description	Material
1	Body	Ductile iron
2	Cylinder retainer flange	Ductile iron
3	Fulcrum bracket	Ductile iron
4	Cylinder	DZR Brass
5	Piston	Bronze
6	Bolt	Stainless steel
7	Float ball	Stainless steel / PP
8	Lever	Steel, stainless / hot dip galvanized
9	Hinge pin	Stainless steel
10	Fulcrum pin	Stainless steel
11	Bushing	Bronze
12	Links	Steel, hot dip galvanized
13	Split pin	Stainless steel / copper
14	Piston seal ring	EPDM rubber
15	Groove for piston seal ring	-
16	O-Ring gasket	EPDM rubber
17	Seat ring	Bronze
18	Main seal	EPDM rubber
19	Valve guide	Bronze
20	Nut and washer	Stainless steel
21	Bolt	Stainless steel
22	Filler cap	Stainless steel / PP
23	Bushing (only certain models)	Stainless steel

### 3. Table of contents

1.	AVK series 854 exploded view .....	2
2.	AVK series 854 parts list .....	3
3.	Table of contents.....	4
4.	Principle of operation.....	5
5.	Health and safety at work .....	5
6.	Receiving and storage.....	6
7.	Installation and commissioning.....	7
8.	Application hazards.....	7
9.	Operation and maintenance .....	8
9.1.	Operation.....	8
9.2.	Maintenance .....	8
9.3.	Seal renewal.....	9
10.	Troubleshooting .....	10
11.	Recommended spare parts .....	10

## 4. Principle of operation

Series 854 Ball Float Valve controls discharge of water into a tank or reservoir in response to water level variations. The float mechanism holds the valve closed until the water levels drops, the float then follows the water level matching inflow to outflow. If the outflow ceases, the water level will rise and the float close the valve.

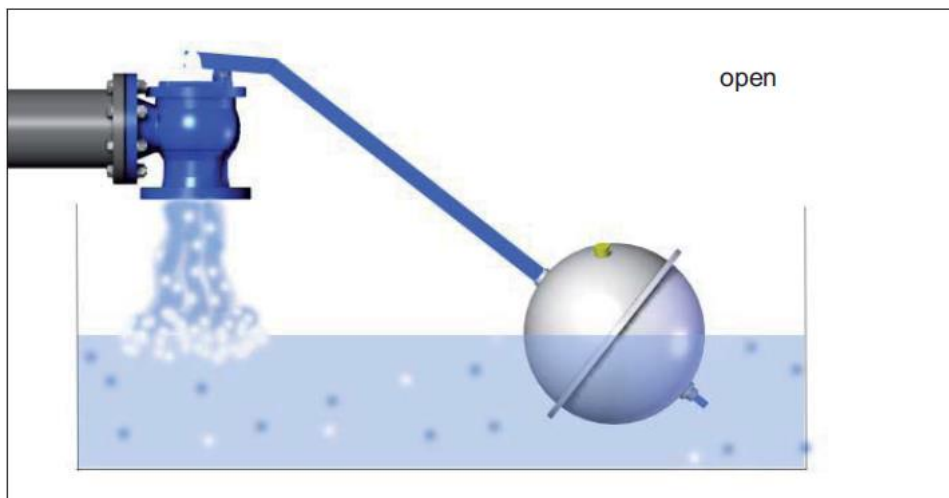
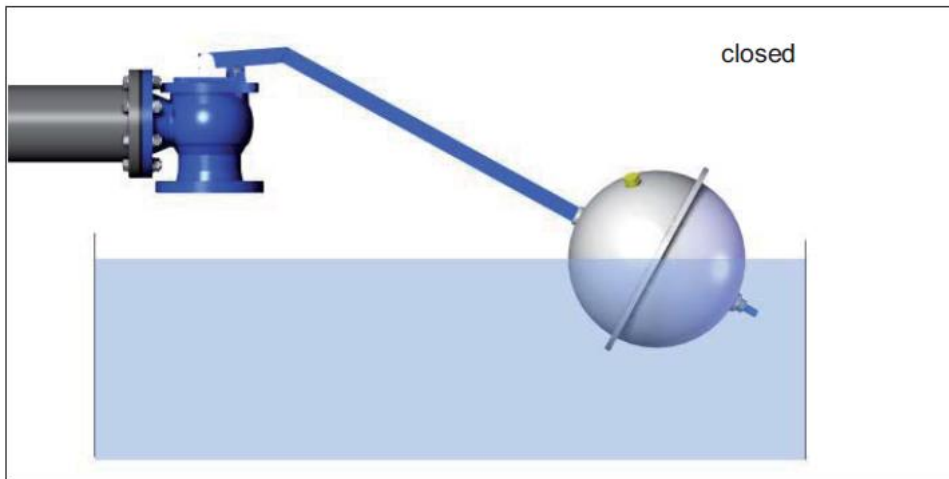

## 5. Health and safety at work

*Make sure all relevant Health and Safety issues and regulations are adhered to prior to and during installation or maintenance work carried out on this product. It is the end user's responsibility to ensure that safe working practices are followed at all times.*

*Whenever AVK's products are installed, operated or maintained the inherent dangers of pressurised liquids and gasses must be addressed. Before work on a valve or other piping component is undertaken, that may involve the release of internal pressure, the valve or line must be fully isolated, depressurised and drained prior to commencing the work. FAILURE TO COMPLY WITH THIS MAY RESULT IN SEVERE INJURY OR DEATH.*

*All workers handling the product must be aware of the weight of the components or assemblies to be handled and manipulated during installation and maintenance.*

*It is essential that staff undertaking these operations are adequately trained and it is the responsibility of the end user that only trained and competent staff undertake these duties.*

*This manual has been designed to assist, but it cannot replace quality training in the workplace. However, the AVK technical staff is always available and ready to answer questions relating to specific problems that may not be covered by this manual.*

*AVK's products are designed to be fit for purpose and to a high reliability standard. This provides a safe, low risk product when used correctly for the purpose for which it was designed. However, this assumes that the equipment is used and maintained in accordance with this manual, and the user is advised to study it and to make it available to all staff that may need to refer to it.*

*AVK cannot be held responsible for incidents arising from incorrect installation, operation or maintenance. The responsibility for this rests wholly with the end user.*

## **6. Receiving and storage**

The valve housing, float and lever are shipped in separate boxes.

Unloading must be carried out carefully. The load must be put gently to the ground without dropping. Lift only by means of shackles in the flange bolt holes or slings around the body casting.

Do not lift the assembled valve in fulcrum pins, fulcrum bracket or float lever.

If a forklift is used it shall have sufficient capacity to lift the required weight and have a valid inspection certificate.

All workers involved in the unloading shall be able to perform their functions. They shall wear safety boots, safety vest, safety goggles and hard hat.

All slings used for the lifting shall be of sufficient strength. A record shall document that they have been stored under cool, dry conditions away from sunlight and chemical atmosphere, and that they still perform according to their marked strength.

Immediately after unloading the item should be inspected for compliance with specifications and damage in shipment.

Compliance with specification check shall as a minimum comprise size, pressure class, flange type and float material.

Damage in shipment check shall as a minimum comprise: coating, seating surfaces, bent levers or shafts, cracked parts, loose bolts, missing parts or accessories or any other evidence of mishandling during shipment.

Each item should be operated through one complete open-close cycle in the position in which it is to be installed.

Storage shall be under dry, cool conditions, away from direct sunlight and corrosive or otherwise chemically active atmosphere.

Make sure the main seal rubber ring is not compressed during storage.

## 7. Installation and commissioning

The valve is sensible to dust and dirt on its upper parts where the piston slides in the cylinder, so if installed outdoors or in a dusty or otherwise dirty environment it must be protected in a suitable valve chamber with sufficient cover from objects and debris falling from above.

Do not install closer than 6 pipe diameters downstream of tees or elbows or other irregularities; this can cause violent turbulence and cavitation inside the valve and reduce its performance and durability.

**WARNING:** *Prior to installation make sure that all pressurized lines involved in the installation are isolated, depressurized and drained before starting any work. Failure to do so may result in sudden pressure release and subsequent severe injury or death.*

- Position the valve housing on the flange and fit the bolts
- Tighten the bolts diagonally in increments to make sure the flanges are kept parallel and finally tighten to correct torque
- Assemble lever and float with the filler cap pointing upwards, install them on the valve housing with the fulcrum and hinge pins and secure them with split pins
- Check for freedom of movement and alignment
- Make sure the valve sealing areas are clean and lubricated with a lubricant suitable for the medium
- If necessary to touch up coating that has been damaged during installation, make sure that no paint is applied to the bearings or sealing surfaces.

When the pipeline has been charged, inspect for leaks and adjust as necessary in accordance with the maintenance instructions.

Operate the valve over a full stroke and check for free movement.

## 8. Application hazards

Unless properly isolated the valve should not be installed in applications where the ambient temperature can reach values below the freezing point of the liquid.

The seals are exceptionally well suited for use with water but exposed to hydrocarbons they will dissolve and render the valve leaking.

Do not use with flammable liquids.

Saltwater and brine will corrode the standard materials used in the valve, but alternative more corrosion-resistant materials may be available; contact AVK for further information.

Operation at max. allowed pressure and very low flow for prolonged periods can cause cavitation and damage to the valve seat.

## 9. Operation and maintenance

### 9.1. Operation

The complete assembly must be able to move freely and easily up and down between fully open and fully closed. Make sure all pin joints and linkages are greased and checked for freedom of movement.

By adding water into the float through the filler cap it is possible to finely adjust the regulated height of the water surface level.

### 9.2. Maintenance

Once every month operate the valve a few times all the way between fully open and fully closed. Check that it shuts completely off when closed.

Once every 6 months clean and lubricate cylinder, pin joints and linkages. Check for wear or damage and for freedom of operation and movement.

**WARNING:** *Prior to any maintenance work that requires disassembly make sure that the pressurized line involved is isolated, depressurized and drained before starting any disassembly. Failure to do so may result in sudden pressure release and subsequent severe injury or death.*

In case the valve does not operate easily check the internals of the valve:

- 1) Support float and lever so that the mechanical load is removed from fulcrum- and hinge pins
- 2) Remove split pins from fulcrum- and hinge pins
- 3) Remove fulcrum- and hinge pins and lift off lever and float
- 4) Remove the fulcrum bracket
- 5) Remove piston assembly
- 6) Inspect piston O-ring/lip seal and valve main seal for wear, damage, cuts, etc.; replace if necessary
- 7) Check links, fulcrum and hinge pins for wear and replace if necessary
- 8) Clean and lubricate seal groove and refit or replace seals
- 9) Inspect valve guide and seat ring for damage or scoring from grit, stones or other debris. Small damages can be smoothed out with a file and emery cloth, but replace part if cuts are deep
- 10) Re-assemble piston components; be careful not to damage the piston O-ring/lip seal
- 11) Make sure the piston can move freely up and down
- 12) Install piston assembly in the cylinder and fit fulcrum bracket
- 13) Install lever/float assembly with new split pins
- 14) Check float for leaks or damage



### 9.3. Seal renewal

1. Remove the piston assembly
2. Remove piston seal ring (14)
3. Clean and lubricate seal groove (15)
4. Check seal ring for cracks or damage, replace if necessary
5. Install seal ring
6. Remove bottom nut (20)
7. Take apart valve guide (19), piston (5) and main seal (18)
8. Check main seal for cracks or damage, replace if necessary
9. Refit seal and assemble the parts
10. Lubricate inner cylinder and piston seal ring with suitable lubricant
11. Reinstall piston assembly with new split pins

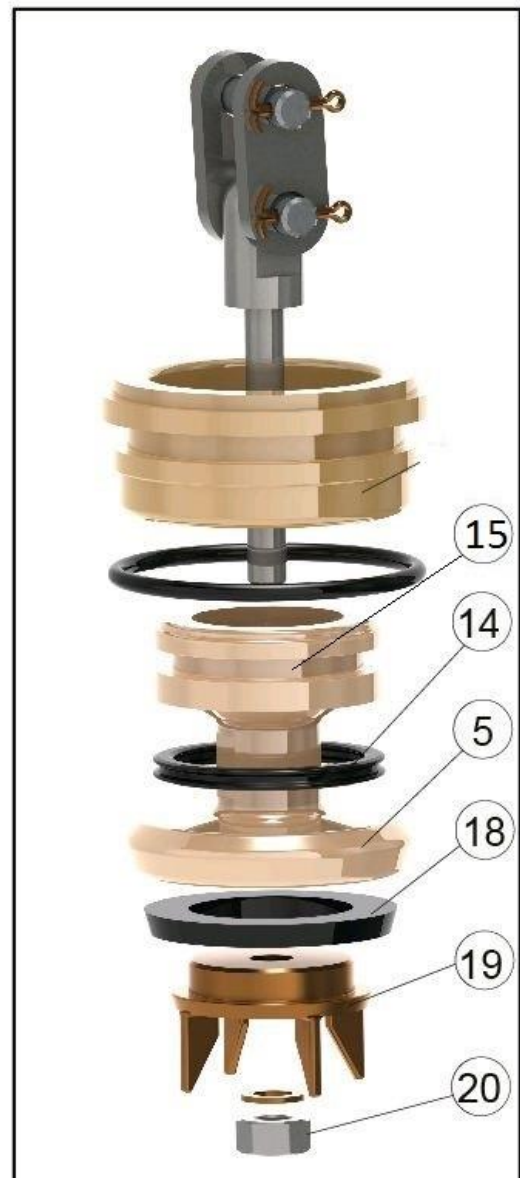
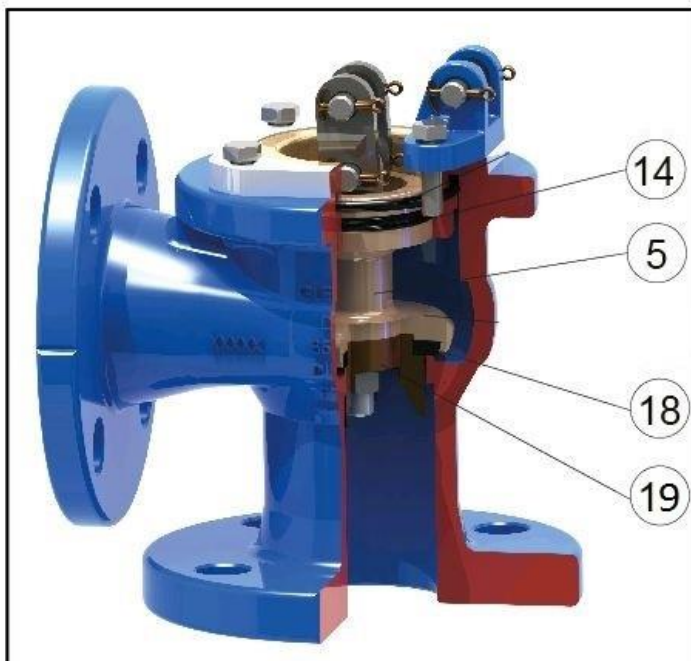

## 10. Troubleshooting

- Symptom: Valve sticks  
Cause: Piston is stuck in the cylinder  
Cure: Disassemble, clean and lubricate the piston assembly. Replace worn or damaged parts
- Symptom: Valve sticks  
Cause: Worn bushings and pins  
Cure: Replace worn parts
- Symptom: Water level is unstable  
Cause: Worn bushings and pins  
Cure: Replace worn parts
- Symptom: Valve leaks from main seal  
Cause: Worn or damaged main seal  
Cure: Replace main seal  
Make sure the liquid is not chemically aggressive to the valve parts and that the pressure/flow combination does not cause cavitation
- Symptom: Valve leaks from main seal  
Cause: Impurities between valve seat and main seal  
Cure: Clean the piston assembly and replace the seal if damaged.  
Install a filter before the valve
- Symptom: Water drips down the valve from its upper side  
Cause: Defective piston seal  
Cure: Replace piston seal
- Symptom: Valve does not close  
Cause: Float leaky and filled with water  
Cure: Replace float  
Check if corrosion is the reason in which case another float material should be considered.

## 11. Recommended spare parts

Only genuine AVK spare parts should be used.

AVK accepts no responsibility for damage caused by failing non-AVK parts.

Following spare parts are recommended to purchase with a ser. 854 valve:

- Seals
- Gaskets
- Lubricants
- Touch up paint