



CSA products for treated water

Water air release valve

Mod. Ventolo

CSA air valve Ventolo

Instructions

These instructions provide installation, operation and maintenance information for CSA Mod. Ventolo automatic air release valve. They are for use by personnel who are responsible for installation, operation and maintenance of CSA Air valves.

Safety Messages

All safety messages in the instructions are flagged with an exclamation symbol and the word Caution, Warning or Danger. These messages indicate procedures that must be followed exactly to avoid equipment damage, personal injury or death. Safety label(s) on the product indicate hazards that can cause equipment damage, personal injury or death.

If a safety sign or symbol becomes difficult to see or read, please contact CSA.



WARNING!

Personnel involved in the installation or maintenance of valves should be constantly alert to potential emission of pipeline material and take appropriate safety precautions. Always wear suitable protection when dealing with hazardous pipeline materials. Handle valves, which have been removed from service, with suitable protection for any potential pipeline material in the valve.

Inspection

Your CSA Ventolo air release valve has been packaged to provide protection during shipment; however, it can be damaged in transport. Carefully inspect the unit for damage upon arrival and file a claim with the carrier if damage is apparent.

Parts

Recommended spare parts are listed on the assembly drawing. These parts should be stocked to minimize downtime. Order parts from your local CSA sales representative if available, or directly from CSA. When ordering parts, please include the model, type and numbers located on the data plate placed on the valve. Also include the part name, the assembly drawing number, and the quantity stated on the assembly drawing.

CSA Service

CSA service personnel are available to maintain and repair all CSA products. CSA also offers customized training programs and consultation services.

For more information, contact your local CSA sales representative if available, or directly CSA. Visit our website at www.csasrl.it.

Table of Contents

Description - - - - -	4
Handling and Storage - - - - -	4
Installation - - - - -	4
Maintenance - - - - -	6
<i>Disassembly Procedure (Air/Vacuum Valve)</i> - - - - -	6
Drawings - - - - -	7
Troubleshooting - - - - -	8
Guarantee - - - - -	9

CSA air valve Ventolo

Description

The CSA automatic air release valve Ventolo is designed to release air pockets in working conditions. This type of air valve should not be considered as a relief for shock conditions and upsurges which develop elsewhere in the system, or a vacuum breaker as the air flow passage is limited to the nozzle, for which other and different CSA models and solutions are available.

The maximum and minimum pressure are stated in the order and according to technical literature. Thanks to the leverism system Ventolo can reach a very low working pressure, in general we recommend to ensure at least 0,1 bar acting on the air valve to ensure the perfect sealing during working conditions.

Handling and Storage

Lifting the valve improperly may damage it. Lift the valve with slings, chains or cables fastened around the valve body, or fastened to bolts or rods through bolt holes in the flanges (if present)

If installation will be delayed, place valve indoors in secure, weather tight storage. If temporary outside storage is unavoidable, make sure a vermin proof rain cover is secured around/over the valve to keep off rain and mud. Skid and set the assembly on a flat, solid, and well drained surface for protection from ground moisture, runoff and pooled rain water. Do not leave the valve exposed to high humidity and excessive temperature conditions.

Installation

The automatic air release valve Ventolo should always be installed in a vertical position. An isolation valve between this unit and the transmission (pipeline) system is necessary to allow maintenance and valve's inspection.

Ventolo has to be used whenever air pockets are likely to accumulate along the pipeline like:

- High points in pipelines
- Change in slope descending
- Long descents
- Long sub- horizontal segments

CSA air valve Ventolo

- This model **should not be** placed adjacent to any pumps, quick closing valve in a pipeline such as a check or gate valve where vacuum and column separation can occur upon closure. For such cases the CSA air valves anti surge vacuum and combination models are suitable and recommended

Note to Engineer: If the air valve is to be installed inside a pump house, use threaded or outlet flanged connections and pipe back into the well or to outside obtained by CSA SUB kit. This will greatly muffle the high noise level caused by the air being discharged and provide for drainage of any small amount of water or water vapour that may accumulate. Same thing applies in case of possible flood events to the installation chamber to avoid the entrance of polluted water



CAUTION!

The air flow passage capacity of Ventolo is limited to the DN of the nozzle, ranging between 1,2 and 3 mm (more on request) depending on the pressure. In case of pipe filling and pipe draining Ventolo won't basically provide any outflow/inflow capacity with the risk of unwanted upsurges and negative pressure conditions sometimes fatal for the system.

- Before installation, remove foreign material such as weld spatter, oil, grease, and dirt from the pipeline.
- Prepare pipe ends and install valves in accordance with the pipe manufacture's instructions for the joint used
- Unless otherwise specified Ventolo is supplied with a threaded connection according to ISO standard (different on request)

Maintenance

The air release valve Ventolo air valve is automatic in operation and requires very little maintenance. It should always be installed in a vertical position with a maximum tilt within 3°. A semi-annual visual inspection for leakage is recommended. A malfunction of the air valve can be identified by the seepage of water through the air release nozzle. Should a malfunction occur, the following steps should be taken to repair the valve;

Disassembly Procedure

See Figures 1 on page 7 for part identification.

1. Relieve pipeline pressure or shut off isolation valve before servicing the Air Valve.
2. Slowly remove the drain port if present to relieve internal pressure (as an option feature Ventolo can be supplied with CSA three ways ball isolation valve provided with automatic pressure relief of the remaining pressure inside the air valve, when isolating it from the main transmission line).



WARNING!

Servicing the air valve while the pipeline is under pressure can cause personal injury or equipment damage. Relieve pipeline pressure or shut off isolation valve before servicing the Valve.

3. Remove cap screws (13) and cap (2), pay attention not to damage the o-ring (3) and check its status for possible wear or damage
4. Pull out the upper cap with the leverism (9) and float (11)
5. Inspect the surface of the float (11) for possible sign of corrosion, deformation, accumulation of dirt
6. Check the proper movement of the lever (9) making sure there is no friction between it and the pivot (8)
7. Should you need to remove the float use the nut (12), otherwise make sure the latter is set tight properly
8. The leverism is composed of an upper lever (7), into which the nozzle (4) is threaded, and a lower lever (9)
9. The leverism system should not be disassembled unless emergencies arise, should that be the case a safety ring (14) has to be removed prior to proceeding further
10. On the lower lever (9) the plane gasket (10) is located, check its surface, clean it and make sure it not torn , damages or punctured
11. Other than the plane gasket (10) the water tightness is obtained by means of the o-ring (3) separating the body (1) from the cap (2) and the two o-rings (6) of the nozzle.
12. The adjusting nut (5) is used to enable customer to adjust the proper compression of the nozzle (4) on the plane gasket (10) and set on the factory prior to shipment and during testing
13. If the nut (5) is removed for maintenance we recommend to adjust the compression of the nozzle once water and pressure is recovered inside the Ventolo to find the suitable position, excessive or insufficient compression of the gasket may lead to leakage

Drawings

Figure 1: Ventolo

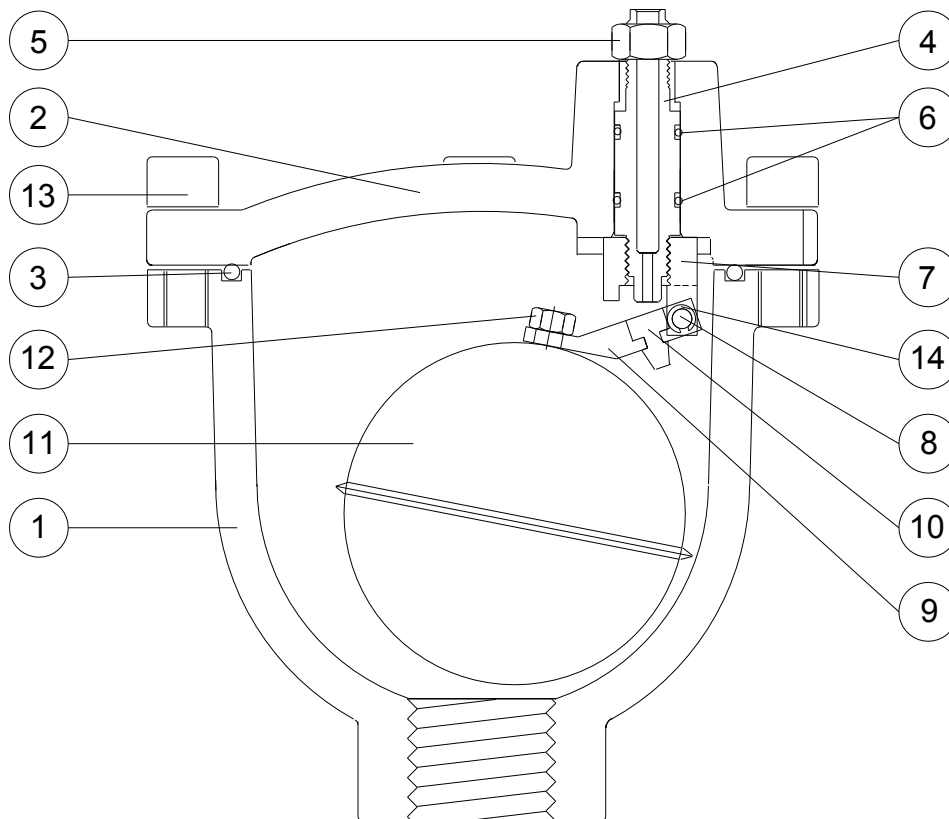

N.	Component	Material
1	Body	GJS 500-7/GJS 450-10
2	Cap	GJS 500-7/GJS 450-10
3	O-ring	NBR/EPDM/Viton/Silicone
4	Nozzle	AISI 303/AISI 316
5	Nut	AISI 304/AISI 316
6	O-rings	NBR/EPDM/Viton/Silicone
7	Upper lever	AISI 303/AISI 316
8	Pivot	AISI 303/AISI 316
9	Lower lever	AISI 303/AISI 316
10	Nozzle gasket	Silicone
11	Float	AISI 304
12	Nut	AISI 304/AISI 316
13	Screws	AISI 304/AISI 316
14	Safety rings	AISI 316
Spare parts: 3-6-10		

Troubleshooting (ref picture 1 on page 7)

Condition	Possible Cause	Corrective Action
Valve leaks at the threaded / flanged connection	Loose flange bolting ((if supplied with flanged connection).	Tighten flange bolting.
	Blown flange gasket (if supplied with flanged connection).	Replace flange gasket.
	Miss-alignment or damage to field piping, supports and inlet threaded connection	Adjust miss-alignment or repair piping, supports and inlet threaded connections
	Damaged flange face/s or improper flange/threaded connections.	Repair flange, replace valve body or adjust flange / threaded connections according to CSA order confirmation and applicable standards
Valve leaks out of the main body (1) and cap (2)	The o-ring (3) is deformed or damaged	Check the o-ring and replace it
	Possible corrosion through the body (1) and cap (2)	Check the fluid chemicals parameters and contact CSA
	No sufficient torque has been exerted on the screws (13)	Exert enough torque when setting the screws (13) tight
	Worn seat and/or float.	Replace seat and/or float.
Valve leaks out of the air release nozzle(4)	Valve is not vertical	Place the valve in a vertical position with a max tolerance of 3°
	Possible corrosion through the nozzle and air release sealing system	Check the fluid chemicals parameters and contact CSA
	Dirt accumulated between the nozzle (4) and the plane gasket (10)	Inspect and clean the nozzle (4) and gasket (10), replace the latter if necessary
	Line pressure is extremely low (below 0,1 bar)	Contact CSA for further assistance
	The float (11) is corroded and/or damaged and full of water with loss of buoyancy	Follow the procedure on page 6 to inspect the float (11) and replace it if necessary

Guarantee

Products, auxiliaries and parts thereof of CSA srl manufacture are warranted to the original purchaser for a period of twelve (12) months from date of shipment from factory, against defective workmanship and material, but only if properly installed, operated and serviced in accordance with CSA srl recommendations. Repair or replacement, at our option, for items of CSA srl manufacture will be made free of charge, (FOB) our facility with removal, transportation and installation at your cost, if proved to be defective within such time, and this is your sole remedy with respect to such products. No claim for transportation, labor or special or consequential damages or any other loss, cost or damage shall be allowed. You shall be solely responsible for determining suitability for use and in no event shall CSA srl. be liable in this respect. CSA srl does not guarantee resistance to corrosion, erosion, abrasion or other sources of failure, nor does CSA srl guarantee a minimum length of service. Your failure to give written notice to us of any alleged defect under this warranty within twenty (20) days of its discovery, or attempts by someone other than CSA srl. or its authorized representatives to remedy the alleged defects therein, or failure to return product or parts for repair or replacement as herein provided, or failure to install and operate said products and parts according to instructions furnished by CSA srl or misuse, modification, abuse or alteration of such product, accident, fire, flood or other Act of God, or failure to pay entire contract price when due shall be a waiver by you of all rights under this warranty.

The foregoing guarantee shall be null and void if, after shipment from our factory, the item is modified in any way or a component of another manufacturer, such as but not limited to, an actuator is attached to the item by anyone other than CSA srl. factory Service personnel. All orders accepted shall be deemed accepted subject to CSA srl warranty terms and conditions.

Limitation of liability

LIMITATION OF LIABILITY: IN NO EVENT SHALL CSA srl BE LIABLE FOR ANY DIRECT, INDIRECT, SPECIAL OR CONSEQUENTIAL DAMAGES WHATSOEVER, AND CSA srl LIABILITY, UNDER NO CIRCUMSTANCES, WILL EXCEED THE CONTRACT PRICE FOR THE GOODS AND/OR SERVICES FOR WHICH LIABILITY IS CLAIMED. ANY ACTION BY YOU FOR BREACH OF CONTRACT MUST BE COMMENCED WITHIN 12 MONTHS AFTER THE DATE OF SALE.

Sales and Service

For information about our service, approvals, certifications:

Web site: www.csasrl.it E-Mail : info@csasrl.it



CSA srl Inc. reserves the right to incorporate our latest design and material changes without notice or obligation.

Design features, materials of construction and dimensional data, as described in this manual, are provided for your information only.